

Digital Wireless Microphone System

DWT-B01
DWR-S01D
DWA-01D



04 System Features

07 DWT-B01
Digital Wireless Transmitter

08 DWR-S01D
Digital Wireless Receiver

10 DWA-01D
Digital Wireless Adapter

11 Specifications & Accessories

Sony Digital Wireless Microphone System

A Breakthrough for a New Level of Sound Quality and Operational Convenience

Since their first introduction in 1974, Sony has been continuously developing a rich range of wireless microphone systems to offer superb audio performance, highly stable transmission and flexible simultaneous multi-channel operation. Nowadays, it can be clearly seen that the industry is migrating from Standard Definition (SD) to High Definition (HD) for video production, as well as from analogue to digital for sound production. This trend naturally boosts the need for higher-quality digital technology in wireless microphone systems.

With the introduction of a new fully digital wireless microphone system, Sony has made a breakthrough in the history of wireless microphone technology. Comprised of the DWT-B01 bodypack transmitter, DWR-S01D slot-in type two-channel receiver and DWA-01D adapter, the system provides excellent-quality digital wireless audio transmission, large-scale, multi-channel operation and enhanced system flexibility – a perfect match for high-quality ENG/EFP applications*¹. Transmission of excellent-quality 24-bit/48 kHz sampling digital audio signals is realised on the DWT-B01 transmitter. The audio codec used in the system was developed specifically for wireless audio transmission, enabling the low-latency, secure and reliable operation that is mandatory for quality-critical applications. In addition, the system allows for an increase of up to 60%*² in the number of simultaneous digital wireless systems in use compared to conventional analogue wireless systems, which gives users enhanced system flexibility. Furthermore, the system offers a metadata-handling capability that provides highly innovative full-wireless remote operations between the transmitter and receiver, dramatically improving operational efficiency.

With its excellent audio quality, system flexibility and operational efficiency, the Sony digital wireless microphone system opens up a whole new world of professional audio applications.

*¹ The digital wireless microphone system is not available in some countries.

*² When operating on an 8 MHz bandwidth TV channel in Europe.



Superb Quality Wireless Transmission

The digital wireless microphone system transmits high-quality 24-bit/48 kHz sampling digital audio signals in a specific frequency bandwidth that meets the wireless-communication regulations of each country. Utilising an original Sony codec, based on Sony's many years of experience in engineering audio products, the system delivers a wide dynamic range of more than 106 dB, a wide frequency response of 20 Hz to 20 kHz and an excellent system latency of 3.6 ms.

Simultaneous Multi-channel Operation

The digital wireless microphone system allows for large-scale multi-channel operations. Thanks to the newly developed digital modulator, the system realises an intermodulation-free, equally spaced channel allocation. The digital wireless transmission technology used in this system enables a significant increase in the number of simultaneous digital wireless systems in comparison with current analogue wireless systems. For example, up to 16 channels of simultaneous operation is possible in an 8 MHz bandwidth TV channel in Europe.

This system also provides the option of using existing WL-800 Series channel plans. In this configuration, the digital wireless system reliably operates alongside the WL-800 Series analogue wireless systems, without concern for having analogue and digital wireless systems interfering with each other.

Stable and Secure Transmission

Incorporating a newly-developed digital modulator, the digital wireless microphone system allows highly stable and secure wireless transmission that is extremely tolerant to RF interference. The system transmits digitally modulated and encrypted data to minimise the risk of interception, providing highly secure transmission. For secure and confidential communication, the system provides two communication modes: peer-to-peer mode and password mode. In peer-to-peer mode, wireless communication between a DWT-B01 transmitter and DWR-S01D receiver can be established by exchanging an encryption key that is generated by the transmitter. In password mode, multiple transmitters and receivers can be configured by setting all devices with the same user-designated password. In addition, this mode supports broadcast communication, which enables multiple receivers to receive audio signals from one transmitter.

Pre-programmed Frequency Groups

To make it easy to choose the correct frequencies for simultaneous multi-channel operation, the optimum intermodulation-free frequencies are stored on each DWR-S01D receiver. These frequencies – all of which have been calculated and tested – are arranged in groups, with each group pre-programmed to allow interference-free operation. The digital wireless microphone system operates within the following frequency ranges:

Frequency range

DWT-B01 transmitter	CE6267	798 to 822 MHz (TV 62 to 64 channels) 838 to 862 MHz (TV 67 to 69 channels)
DWR-S01D receiver	CE62	798 to 822 MHz (TV 62 to 64 channels)
	CE67	838 to 862 MHz (TV 67 to 69 channels)

* The DWR-S01D receiver supports a 24 MHz band RF carrier frequency range. When using the DWR-S01D receiver in either the 798 to 822 MHz (TV 62 to 64 channels) or 838 to 862 MHz (TV 67 to 69 channels) frequency range, please contact your nearest Sony office or authorised dealer.

Metadata Transmission

In addition to audio signals, a variety of information about the DWT-B01 transmitter – such as audio input peak level, remaining battery capacity, low-cut filter frequency and attenuator level – can be wirelessly transmitted to the DWR-S01 receiver as metadata. This allows users to monitor the status of the transmitter from the DWR-S01D receiver, offering high operational convenience.

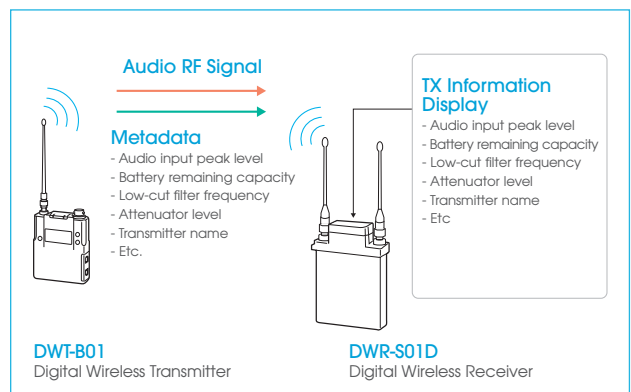

Innovative Wireless Remote Control

Wireless remote control capability of the Sony digital wireless microphone system is one of the most distinctive user features that digital transmission technology has made possible.

A variety of DWT-B01 transmitter settings – such as power on/sleep, attenuator level, low-cut filter frequency and RF power output level – can be wirelessly controlled from the DWR-S01D receiver. This is highly convenient because setting changes can be made very easily even after the transmitters are attached to an actor or reporter.

Furthermore, when the DWR-S01 receiver is used with the PDW-700 XDCAM™ HD camcorder, users can monitor the status of the digital wireless microphone system through the camcorder's viewfinder. They can also wirelessly control the settings of the DWT-B01 transmitter via the camcorder menu.

This wireless control makes use of 2.4-GHz IEEE802.15.4 communication technology, which is commonly available worldwide. Communicating via this wireless remote technology in no way affects the audio or RF signals of either the digital or analogue wireless microphone systems. In addition, it is ideal for large-scale multi-channel system management and is effective for low power consumption.

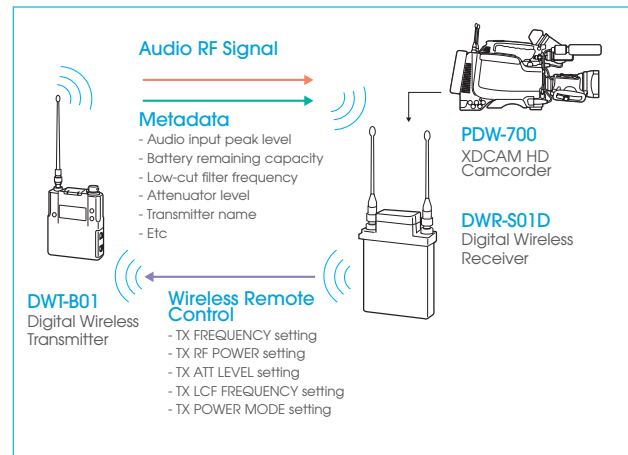

Services from Sony

Services from Sony: working with you, working for you.

Recognising that every company and every challenge is unique, we offer a complete and comprehensive range of services all the way through consulting, planning, financing, implementation, training, servicing, maintenance and support. Choose exactly what's right for you, when and where you need it.

Sony Professional Services Tailor-made design, installation and project management of audio-visual and IT (AV/IT) systems using skills developed over 25 years of systems integration.

Sony Financial Services Innovative and flexible finance solutions designed to meet budgetary and financial requirements and constraints, enabling businesses to always have the most current technology.

Sony Training Services A range of off-the-shelf or customised training services from basic operation through to high-level technical maintenance.

Sony Support Services Fully integrated and customised support for products and systems throughout their operational life, combining proactive and reactive technical services

Not all services are available in all countries. If you'd like to find out more about what we do, who we do it for and how we do it, visit www.sonybiz.net or contact your local Sony office.

06 System Features

Easy-to-see, Full Dot-matrix OLED (Organic Light-Emitting Diode) Display

The DWT-B01 transmitter and DWR-S01D receiver have an easy-to-see OLED display, providing a variety of information such as operating channel/frequency, AF input level, RF output level and battery status. The quick response of the OLED display enables real-time operating conditions, such as the audio level meter, to be displayed clearly and accurately. In addition, the OLED provides a high level of visibility even in low-temperature or low-light environments.

DWT-B01



DWR-S01D



USB Interface

The DWT-B01 transmitter and DWR-S01D receiver come equipped with a USB interface. This is used to connect a USB keyboard, from which users can easily change a variety of settings. In addition, by connecting the transmitter and receiver directly to each other via the supplied USB cable, the encryption keys required for confidential peer-to-peer communication can be exchanged manually or automatically.



DWT-B01

DIGITAL WIRELESS TRANSMITTER

Wide RF Carrier Frequency Range

The DWT-B01 transmitter covers an extremely wide RF carrier frequency range; much wider than the 24 MHz band of the analogue wireless microphone system. The CE6267 model can cover a 48 MHz band*¹. This remarkably wide coverage on a single model offers cost efficiency and operational convenience, because it allows one transmitter to be operated in many different countries.

*¹ The DWR-S01D receiver supports a 24 MHz band RF carrier frequency range, 798 to 822 MHz (TV 62 to 64 channels) and 838 to 862 MHz (TV 67 to 69 channels).

Selectable RF Output Power (1/10/50 mW)

The DWT-01B transmitter provides a choice of RF output powers. The 1 and 10 mW output is suitable for multi-channel operations such as theatre and studio productions, while the 50 mW output is intended for long-distance transmissions such as sports and news coverage.

Power Sleep Mode

The DWT-B01 transmitter is equipped with a power sleep/wake up mode that can be wirelessly controlled from the DWR-S01D receiver. Wherever the transmitter is attached – for example, inside an actor's costume – the operator can remotely control the transmitter's power on and sleep settings, increasing operational convenience and battery savings.

Digital Low-cut Filter

Equipped with a digital low-cut filter, the DWT-B01 transmitter can reduce the effects of undesired ambient noise.

Accommodates Various Types of Battery

The DWT-B01 transmitter can be operated with either alkaline, lithium, or nickel-metal hydride batteries. The transmitter will operate continuously for approximately four* hours when using two Sony AA-size alkaline batteries at 25 °C (77 °F) and 10 mW output power.

* The operating time may vary depending on the operational environment.



Lightweight and Rugged Design

The DWT-B01 transmitter is designed to be extremely compact and lightweight, essential qualities for users in fast-moving TV and outdoor productions. It measures 63 x 73 x 17 mm and weighs just 125 g including the battery. In addition, its robust die-cast magnesium body allows the DWT-B01 transmitter to withstand even the harshest of operational environments.

Switchable Mic or Line Input Level and Adjustable Attenuator

The audio input level of the DWT-B01 transmitter is selectable from either MIC or LINE. When MIC is selected, the attenuator can be adjusted in 3-dB steps from 0 dB to 48 dB. The reference input level of the MIC and LINE is -58 dBu (-60 dBV) and +4 dBu, respectively.

Dimensions

Unit: mm (inches)

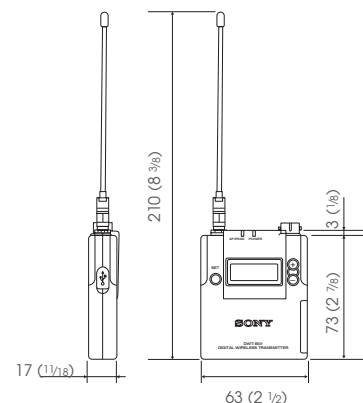

08 DWR-S01D

DIGITAL WIRELESS RECEIVER

Industry-first Two-channel Slot-in Wireless Receiver

The DWR-S01D is an industry-first two-channel digital wireless receiver that offers an ideal solution for high-quality ENG and EFP applications. Despite its dual-channel receiver capability, the DWR-S01D receiver is small enough to be mounted directly in the slot of the Sony PDW-700 XDCAM HD camcorder, maintaining the well-balanced design and compactness of the camcorder. Through the direct mount, high-quality digital audio transmitted from a DWT-B01 transmitter can be recorded directly to the camcorder via a D-sub 15-pin interface without the need for any signal conversions.

Rear Mounting to Camcorders

In addition to the slot-in capability for the PDW-700 XDCAM HD camcorder, the DWR-S01D receiver can be rear-mounted to a range of Sony professional camcorders – such as the HDCAM™, XDCAM, XDCAM HD, Digital Betacam™ and MPEG IMX™ Series camcorders – using the DWA-01D adapter. When used with a camcorder that has AES/EBU inputs, full-digital audio recording is also possible.



PDW-700
XDCAM HD Camcorder



Sony Professional Camcorder
with Wireless Receiver Slot

Compact, Lightweight and Rugged Design

Despite having a number of stunning functionalities, such as its dual-channel receiver capability, the DWR-S01D is still highly compact and lightweight – just like the existing analogue, single-channel wireless receiver WRR-855S/855B. It measures only 88 x 117.8 x 31.3 mm and weighs just 280g (9 oz), maintaining good balance even when mounted on a camcorder. In addition, the DWR-S01D is made of magnesium die-cast and aluminum, making it extremely rugged and suitable for the harsh environments of even the most demanding ENG/EFP applications.

Auto Channel Scanning Functions

The DWR-S01D receiver comes with two auto channel scanning functions that allow for fast, easy and safe frequency channel changes. Clear Scan mode automatically seeks unoccupied channels, from which operators can select the most appropriate channel to use. While Active Channel mode searches for channels that are currently in use, allowing operators to check whether the channel is used by a transmitter in the same operational group or by other equipment that may interfere with the digital wireless transmission signal.

Wireless Remote Control

The wireless remote control is an extremely efficient feature that enables the DWR-S01D receiver to control various settings of the DWT-B01 transmitter such as power on/off, attenuator level, low-cut filter frequency and RF power output level.

An Introduction to Digital Wireless Microphone Technology is now available.

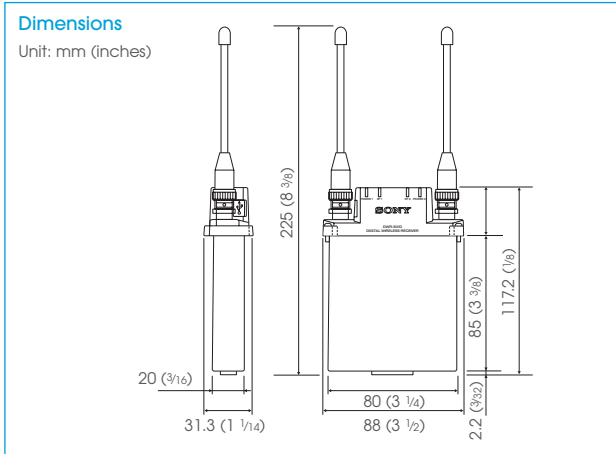
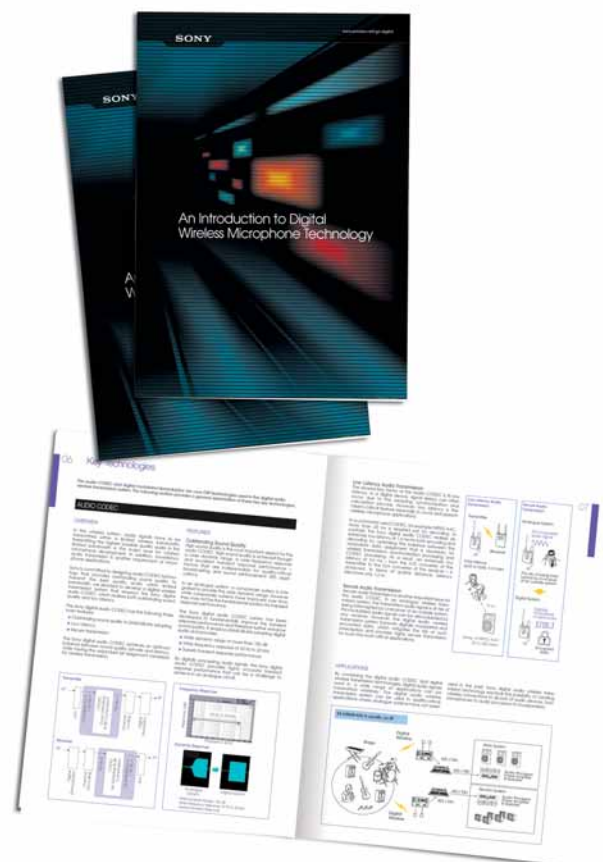

Contact your local Sony office
to request a copy or download
a PDF version from
www.sonybiz.net/go-digital

10 DWA-01D

DIGITAL WIRELESS ADAPTER

Camcorder Rear-mount Operation*1

The DWA-01D adapter allows the DWR-S01D receiver to be rear-mounted on a range of Sony professional camcorders, such as HDCAM, XDCAM, XDCAM HD, Digital Betacam and MPEG IMX camcorders. In addition, the DWA-01D adapter can be used with the current analogue wireless receiver WRR-855S/855B.*2

*1 Requires an optional mount bracket (A-8278-057B).

*2 Output from the DWA-01D and WRR-855S/855B is one-channel analogue audio signal only.

Stand-alone Wireless Receiver Operation

In addition to camcorder mounting, the DWR-S01D receiver with DWA-01D adapter can also work as a stand-alone wireless receiver.* This, in combination with a digital audio mixer such as the Sony DMX-P01, creates a compact, portable, EFP digital wireless microphone system.

* Requires DC power supply from a connected unit via a 4-pin connector.

Wide Array of Interfaces

The DWA-01D adapter comes equipped with a wide range of interfaces optimised for diverse operational needs:



- > SMC9-4S (Sony 4-pin) (x 2): Outputs either AES/EBU or analogue audio signals
- > Word Sync input: Allows the digital wireless microphone system to synchronise with an external word sync signal
- > Stereo headphone output: Offers easy monitoring of the output sound (switchable between Tuner 1/Tuner 2/Mixed)

DWA-01D Supplied Accessories



Unique Lock-together Mechanism

The DWA-01D adapter is equipped with a connecting bracket that allows two DWA-01D adapters to be easily combined. This is particularly convenient for when two pairs of the DWR-S01D receiver and DWA-01D adapter are used at the same time as a stand-alone four-channel receiver system.

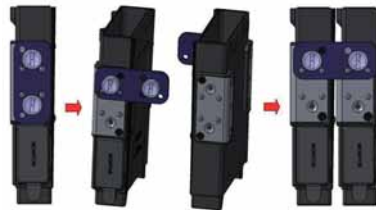

Dimensions

Unit: mm (inches)

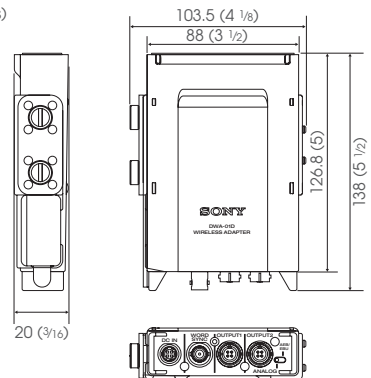

SYSTEM SPECIFICATIONS

Sampling frequency		48 kHz
Quantisation bit length		24 bit
Reference input level (at 0-dB audio attenuator level)	MIC	-58 dBu, 1 kHz (-60 dBV, 1 kHz)
	LINE	+4 dBu, 1 kHz
Reference output level	Analogue output	-58 dBu
	AES/EBU output	-36 dBfs/-20 dBFS switchable
Maximum output level	Analogue output	-22 dBu
	AES/EBU output	0 dBfs
Frequency response		20 Hz to 20 kHz
Dynamic range		106 dB typical (A-weighted, T.H.D = 1%)
Distortion (T.H.D)		0.03% or less
Modulation method		$\pi/4$ Shift QPSK
Audio delay		3.6 ms
Remote control		2.4 GHz IEEE802.15.4 compliant
USB		USB 2.0 compliant

DWT-B01

TRANSMITTING SECTION

Oscillator		Crystal controlled PLL synthesiser
Carrier frequency range	CE6267	798 to 822 MHz (TV 62 to 64 channels) 838 to 862 MHz (TV 67 to 69 channels)
Channel step		25 kHz
RF power output		1 mW/10 mW/50 mW (e.r.p.) selectable
Occupied RF bandwidth		192 kHz
Audio delay		1.5 ms

AUDIO SECTION

Maximum input level	MIC	-22 dBu (with 0 dB attenuator)
	LINE	+24 dBu
Audio attenuator adjustment range (pad)		0 to 48 dB (3 dB steps, MIC input mode only)
Input connector		Sony 4-pin (SMC9-4S) (x1)
Input impedance		4 k Ω or more

GENERAL

Operating voltage		DC 3.0 V, (two LR6 AA-size alkaline batteries)
Battery life		Approx. 4 hours at 10 mW output (at 25 °C (77 °F), with Sony LR6 AA-size alkaline batteries)
Dimensions (W x H x D)		Approx. 63 x 73 x 17 mm excluding projection
Mass		Approx. 125 g including batteries
Supplied accessories		Soft case (x1), Spare battery case (x1), Microphone cable (4-pin to XLR-3-pin) (x1), USB adapter cable (x1), USB cable (x1), Carrying case (x1), Frequency list (x1), Operating instructions (x1)

DWR-S01D

TUNER SECTION

Type of reception		Space diversity
Circuit system		Dual conversion superheterodyne
Receiving frequency range*	CE62	798 to 822 MHz (TV 62 to 64 channels)
	CE67	838 to 862 MHz (TV 67 to 69 channels)
Channel step	CE62/CE67	25 kHz
Local oscillators		PLL synthesiser
RF input terminal		BNC-R, 50 Ω
Sensitivity		20 dBu or less (at bit error rate=1 x 10 ⁻⁵)
Audio delay		2.1 ms

AUDIO SECTION

Audio output connector		D-sub 15-pin (x1)
------------------------	--	-------------------

GENERAL

Dimensions (W x H x D) excluding projection		Approx. 88 x 117.8 x 31.3 mm
Mass		Approx. 280 g
Supplied accessories		Whip antenna (x2), USB cable adapter (x1), USB cable (x1), Frequency list (x1), Operating instructions (x1)

DWA-01D

AUDIO SECTION

Output connector		Sony 4-pin (SMC9-4S) (x2) (OUTPUT1, OUTPUT2)
Analogue audio output impedance		150 Ω or less
AES/EBU audio output impedance		75 Ω
WORD SYNC input		BNC-R, 75 Ω , lockable range: 32 to 54 kHz
Monitor output connector		ϕ 3.5 mm stereo mini-jack
Monitor output level		5 mW (at 16 Ω load, T.H.D=1%)

GENERAL

Power requirements		DC 12 V
Operating voltage		DC 3.6 to 17 V
Dimensions (W x H x D)		Approx. 88 x 138 x 31.5 mm excluding projection
Mass		Approx. 250 g
Supplied accessories		Audio cable (x2), DC cable (x1), Mount plate kit (x1), Operating instructions (x1)

Optional Accessories



ECM-88BC
Lavalier Microphone



ECM-77BC
Lavalier Microphone



ECM-66BC
Lavalier Microphone



ECM-44BC
Lavalier Microphone



ECM-166BC
Lavalier Microphone



ECM-322BC
Headset Microphone



F-112
Dynamic Microphone



DMX-P01
Digital Portable Mixer



A-8278-057-B
Mounting Bracket

* The DWR-S01D receiver supports a 24 MHz band RF carrier frequency range. When using the DWR-S01D receiver in either the 590.125 to 607.875 MHz (TV 34 to 36 channels), 614.125 to 637.875 MHz (TV 38 to 41 channels) or 662.125 to 697.875 MHz (TV 46 to 51 channels) frequency range, please contact your nearest Sony office or authorized dealer.

SONY

Specialist

Dealer

Sony Specialist Dealers receive extensive training on all our products and services. They combine this with an in-depth knowledge of the market, ensuring you get advice that meets your needs before and after purchase. To find your nearest Sony Specialist Dealer visit our "dealer locator" at:

www.sonybiz.net/dealer